

# Eclipse ThermJet Burners

## for Preheated Combustion Air

Model TJPCA0075

Version 2

Parameter			Specifications		
			Natural Gas	Propane	Butane
<b>Maximum Input BTU/hr (kW)</b>			750,000 (220)	750,000 (220)	750,000 (220)
<b>Minimum Input, On-Ratio BTU/hr (kW)</b>			75,000 (22)	75,000 (22)	75,000 (22)
<b>Gas Inlet Pressure Required "w.c. (mbar) Fuel Pressure at Gas Inlet</b> <i>(Tap "B" - see page 3)</i>	<b>Combustion Air Temp</b>	<b>Ambient</b>	7.2 (17.9)	10.2 (25.3)	9.7 (24.1)
		<b>300°F (150°C)</b>	8.4 (20.8)	11.5 (28.6)	11.1 (27.5)
		<b>700°F (370°C)</b>	10.5 (26.1)	13.9 (34.4)	13.6 (33.8)
		<b>1000°F (540°C)</b>	12.1 (30.1)	15.7 (38.9)	15.8 (38.5)
<b>Air Inlet Pressure Required "w.c. (mbar) 15% Excess Air at Maximum Input</b> <i>(Tap "A" - see page 3)</i>	<b>Combustion Air Temp</b>	<b>Ambient</b>	3.8 (9.5)	3.8 (9.5)	3.8 (9.5)
		<b>300°F (150°C)</b>	5.4 (13.5)	5.4 (13.5)	5.4 (13.5)
		<b>700°F (370°C)</b>	8.3 (20.7)	8.3 (20.7)	8.3 (20.7)
		<b>1000°F (540°C)</b>	10.5 (26.2)	10.5 (26.2)	10.5 (26.2)
<b>High Fire Flame Length Inches (mm)</b> <i>(Measured from End of Combustor)</i>			<28.0 (711)	<38.0 (965)	<38.0 (965)
<b>Flame Detection</b>			UV scanner available for all combustors.		
<b>Fuel</b> <i>For any other mixed gas, contact Eclipse for orifice sizing.</i>			Natural gas, propane, or butane		

- All information is based on laboratory testing in neutral (0.0" w.c.) pressure chamber. Different chamber size and conditions may affect the data.
- All information is based on standard combustor design. Changes in combustor will alter performance and pressures.
- All inputs based upon gross calorific values.
- Eclipse reserves the right to change the construction and/or configuration of our products at any time without being obliged to adjust earlier supplies accordingly.
- Plumbing of air and gas will affect accuracy of orifice readings. All information is based on generally acceptable air and gas piping practices.

# Performance Graphs

## Operational/Ignition Zone

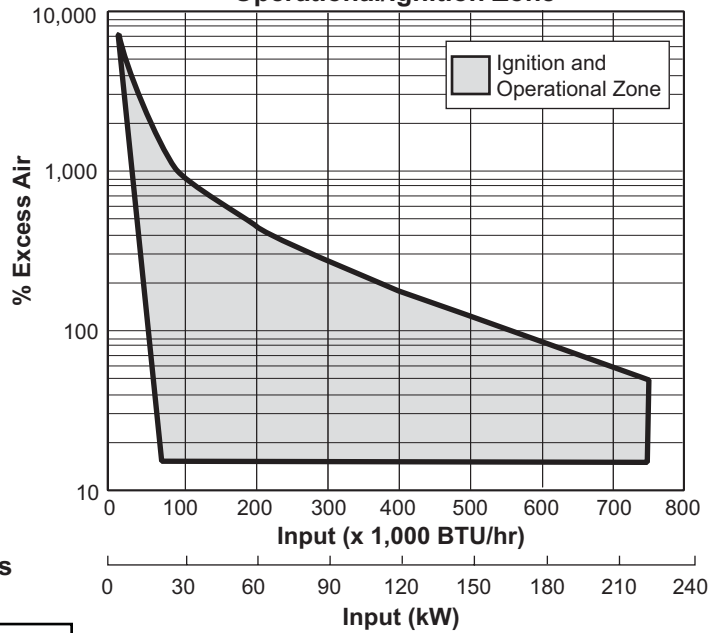

## NO<sub>x</sub> vs Preheated Air Temperatures (Based on Maximum Firing Rate)

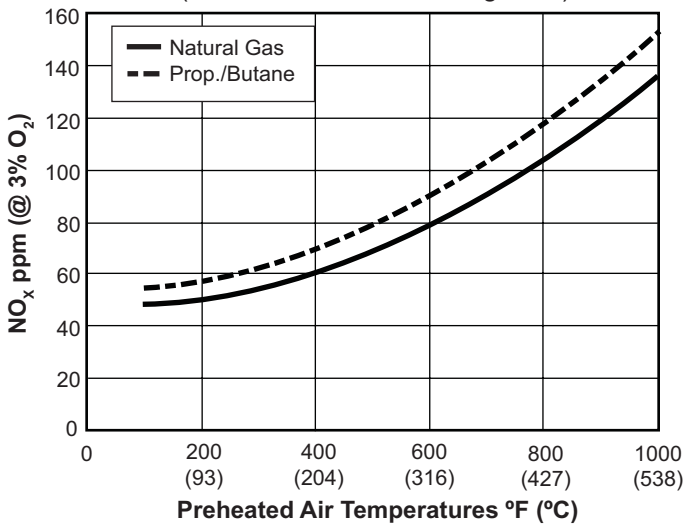

Emissions from the burner are influenced by:

- Fuel type
- Combustion air temperature
- Firing rate
- Chamber conditions
- Percent of excess air

For estimates of other emissions, contact Eclipse.

## Gas Orifice ΔP vs. Input (Measured from Tap B to Tap D)

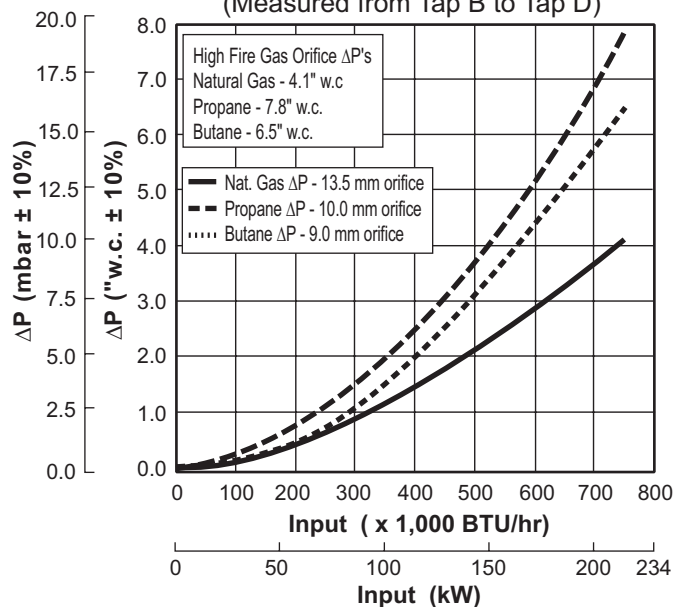

## Dimensions in inches (mm)

### Burner Housing

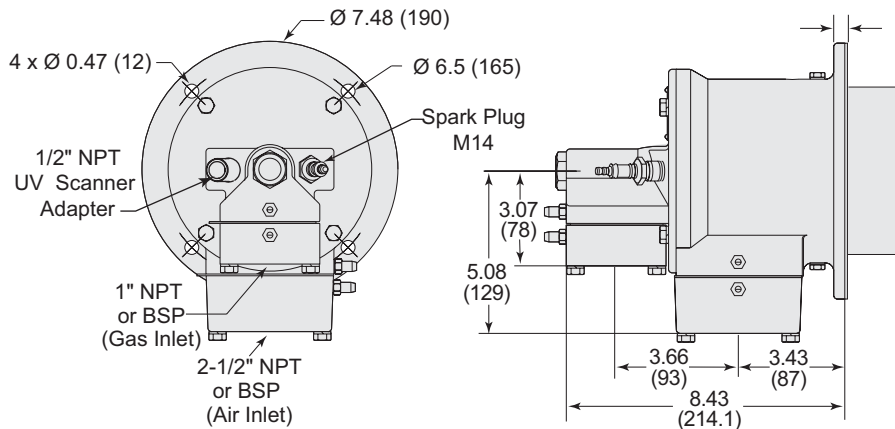

Burner weight less combustor: 37 lbs (17 kg)

### Tap Locations

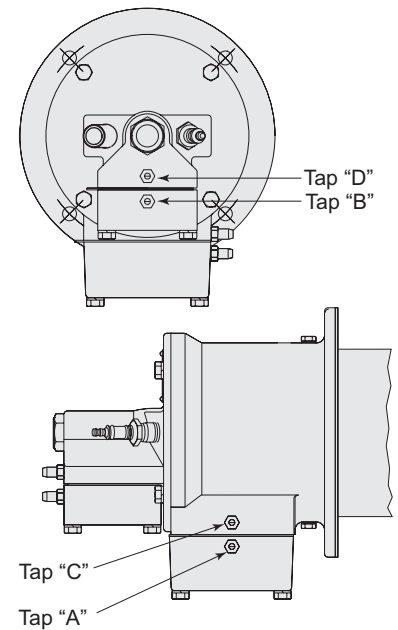

## Combustor

Exhaust Outlet Diameter - Medium Velocity:  $\text{Ø } 2.91$  (74)

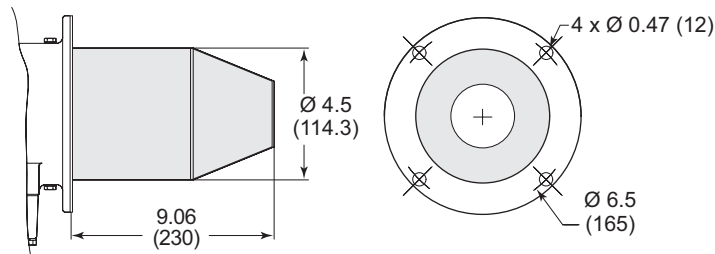

#### **Alloy Tube (AISI 310)**

Weight: 3.0 lbs (1.36 kg)  
 Max Chamber Temp: 1,750°F (950°C)  
 (Not suitable for preheated air over 700°F)

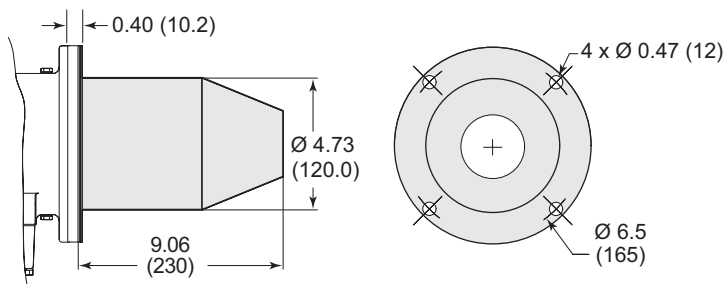

#### **Silicon Carbide Tube**

Weight: 3.3 lbs (1.5 kg)  
 Max. Chamber Temp: 2,200°F (1200°C)

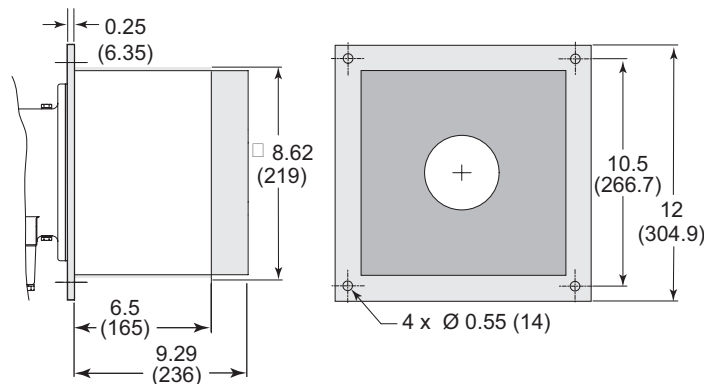

#### **Refractory Block**

(w/RA330 wrapper)  
 Weight: 62.5 lbs (28.3 kg)  
 Max Chamber Temp: 2,800°F (1538°C)

# Down Firing Block

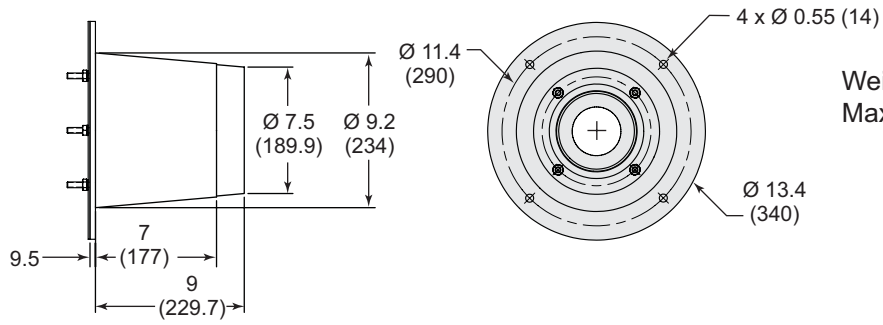

Weight: 60 lbs (27.22 kg)  
Max. Chamber Temp: 2800°F (1535°C)



**Offered By:**

Power Equipment Company  
2011 Williamsburg Road  
Richmond, Virginia 23231  
Phone (804) 236-3800  
Fax (804) 236-3882

---

[www.peconet.com](http://www.peconet.com)